



arkè®

by **ALBINI & FONTANOT®**

English

ASSEMBLY INSTRUCTIONS

CIVIK ZINK



Ø 8x300 12x120 14x150 mm



Ø 2.5 3.5 4.5 9 mm

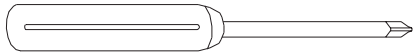

PH 2

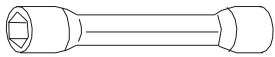
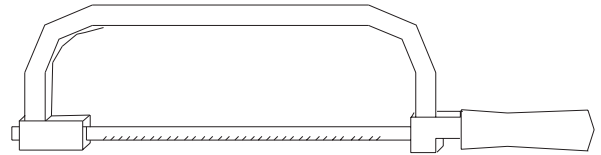
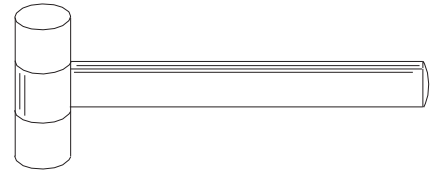

12/13 mm

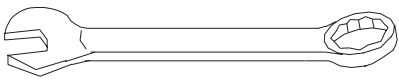
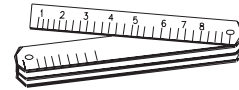

13 17 19 30 mm

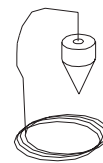

2.5 3 5 12 mm

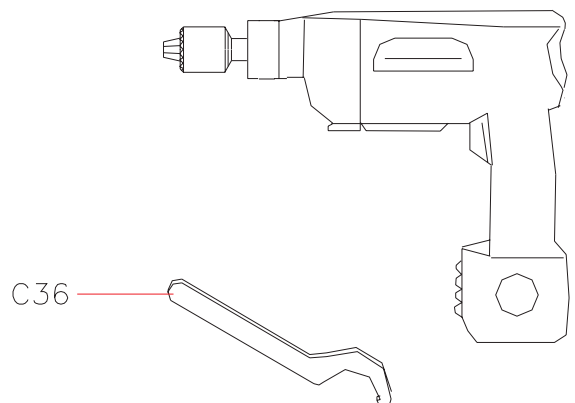
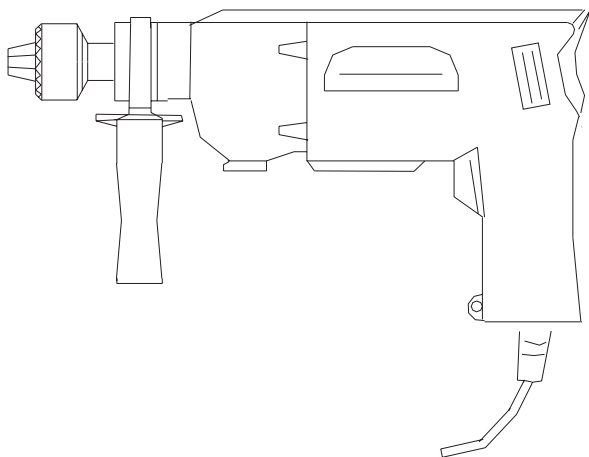
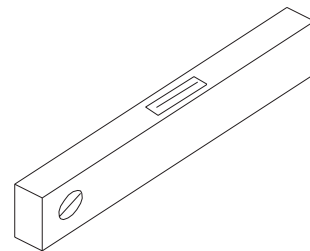

Before starting the assembly process, unpack all components of the staircase. Lay them out on a large surface and check the quantity of all the pieces, by consulting the table TAB.1 (A = Code, B = Quantity). Inside the staircase box you will also find a video tape which we suggest watching before proceeding to assemble. For the USA only: call the customer support line at 1-888 STAIRKT, should you have any case of need.

Preliminary Assembly

1. Insert the elements C13 and C31 into the cylinders D32. Assemble the cylinders D32 into the treads (L02) by using the elements D33. Tighten by means of the article C36.
2. Carefully measure the floor-to-floor height and determine the required number of spacers (D03) (TAB.2).
3. Assemble the spacers (D14, D03, D02) together in one piece. Do the same for the spacers (D04, D03, D02).
4. Assemble the base G03, B17 and B46 (fig. 1).

Assembly

5. Determine and mark on the floor the fixing point of the base (G03+B17+B46) by laying the landing (E03) on the ceiling (fig. 3).
6. Place the base (G03+B17+B46) and drill with drill bit 14 (fig. 3).
7. Fix the base (G03+B17+B46) onto the floor with the parts B13.
8. Screw the pole (G02) into the base (G03+B17+B46) (fig. 1).
9. Insert the base cover (D05) (fig. 4).
10. Insert the spacers (D14+D03+D02) (fig. 4).
11. Insert the first tread (L02) into the pole (G02). Then continue with the assembly, by adding alternatively one spacer (D04+D03+D02) and one tread (L02). At this stage, the treads have to be positioned alternately one to the right and one to the left, so as to distribute the weight in a balanced way (fig. 4).
12. When you reach the end of the pole (G02), screw the part B47 on it, then add the second pole (G02) and continue with the stair assembly (fig. 4)
13. When you reach the end of the pole (G02), screw on it the part B46 and the part G01 (screw the part G01, till its upper end sticks out approximately 15cm (6") from the stair height. Continue adding the treads, by using the part D01 inserted into the spacers (D04+D03+D02) (fig.5).
14. Finally add the stair landing (E03). Fasten the parts B05, B04 and screw the part B03 sufficiently, keeping in mind that the treads still have to rotate (fig. 1).

Fitting of the Landing

15. Drill with drill bit 14 in relation to the holes.
16. Block the part B13 completely (fig. 1).

Assembly of the Railing

17. Spread-out the treads (L02) fan-like, after having chosen the rotation direction (fig. 6). It is now possible to use the stair.
18. Starting from the landing (E03), insert the first long railing baluster (C07): 1) measure the rise between the tread (L02) and the landing (E03) and add 2,5cm (1"), 2) cut the final part of the long baluster (C07), 3) pierce with the drill bit 9 the landing (E03), 4) assemble the parts F01 using the parts B07 and B23, 5) insert the just cut baluster part between the lower part F01 and the tread (L02), 6) tighten the parts C31 of the tread and of the landing, 7) insert and fasten with the part C31 the resting part of the baluster (C07) into the upper part F01 (fig. 1). Turn the balusters (C07) maintaining the holes looking to the stair centre.
19. Insert the longer balusters (C07), which connect the treads (L02), one by one. Tighten only the part C31 of the lower tread (fig. 2).
20. Check the vertical position of all the assembled balusters (C07). This control is very important for best results.
21. Tighten securely the part B03 (fig. 7).
22. Tighten securely the part C31 of the upper tread (fig. 2).
23. Check once more the vertical position of the railing balusters (C07) and, if necessary, correct it, by repeating the previous operations.
24. Set the first baluster (C07) together with the reinforcing part (C30). Cut one long baluster (C07) to obtain the same size as all others you assembled previously (fig. 1).
25. Fix into the floor in relation to the first baluster (C07), the part F01, by piercing with the drill bit 8. Use the parts B11, B12, C29 and C31 (fig. 1).
26. Warm the handrail (A02) until it becomes malleable: 1) put the handrail onto the cover of the wooden box, 2)

warm for about five minutes making circular movements continuously without holding on, 3) turn it on its other part and repeat that operation.

27. Set the handrail (A02) onto the balusters (C07) starting from the top before it becomes cold (fig. 7).
28. Drill the handrail (A02) in relation to the present holes and fasten with the parts B54 and B55.
29. Insert quickly all the other balusters, paying attention to their vertical position, into the treads (L02), tighten the part C31 and fasten to the handrail (A02) using the parts B54 and B55 (for the stairs with a diameter larger than 140cm (4' 7 1/8"), it is advisable to assemble first the shorter balusters).
30. Cut the excess piece of the handrail (A02) in relation to the first railing baluster (C07).
31. Complete the handrail (A02) by assembling the parts A03. Use the glue (X01) (fig. 1).
32. Complete the railing assembly inserting the parts B82 into the lower part of the balusters (C07) (fig. 1).

Assembly of the Balustrade

33. Screw the baluster (C04) into the part G01 that sticks out from the landing (E03) (fig. 1).
34. Assemble the parts F01, using the parts B89, B27, B23 into the holes of the landing (E03), maintaining a similar distance as between the balusters (C07) of the railing, which had been assembled previously. (fig. 1).
35. Place the shorter balusters (C07) in part F01, applying some silicone in order to seal the space between the two elements and to tighten part C31.
36. Fix the part B01 into the baluster (C04), by using the part C31 and some silicone (fig. 1).
37. Fix the handrail (A02), using the parts B54 and B55 (fig. 1).
38. In case that there are walls around the stair well and on their position, it could be necessary to position one or two more balusters.
39. In that case it is necessary to consider either the distance between all other balusters, or otherwise the distance from the wall. For the fixing it is suggested to pierce with a drill bit 9 the landing (E03) and to use the fixing parts F01, C31, B89, B27, B23 (fig. 10).

Final Assembly

40. In order to re-inforce the staircase at the intermediate points, you must fix into the wall the parts F09 and connect them to the balusters (C07) by means of the parts F08. Pierce the wall with a drill bit 8 and use the parts B36, B37, B11, B12 (fig. 11).

Characteristics of staircases for outdoors

Arke products are made of excellent quality and treated with the best technological process; the staircase model CIVIK ZINK, especially, has the following features:

stainless steel screws

balusters made of pre-galvanized sheet with the addition of cold galvanizing on the welded joints.

treads and landing are welded by a welding robot and they are hot-dip galvanized on 450° after degreasing and passivation in full respect of normative standards UNI E 14.07.000.0 and certification ISO 9002.

It's a usual feature of the hot-galvanized products to present small areas in which the zinc is not perfectly stucked.

It's also possible to damage the galvanized surface during the assembly.

To guarantee a long life product, you will find a kit of liquid zinc in the box to lay on with a brush for possible retouches after the assembly.

We suggest to check the wholeness of your staircase at regular intervals, and to retouch possible damaged areas with similar products easily to be found on the market.

It's a usual feature of the hot-galvanized products that they become matt after some time, that's because of a normal oxidation process of the zinc in all weather conditions.

The staircase may be painted immediately after a preventive application of a suitable primer or, without any particular cautions, after an exposition to weather conditions of at least 12-18 months.

We would be grateful, if you could send us any possible suggestion by visiting our Internet Site:

www.arke.ws

TAB. 1

A	B		
	<u>Ø 120</u> 3' 11 1/4"	<u>Ø 140</u> 4' 7 1/8"	<u>Ø 160</u> 5' 3"
A02	1	1	1
A03	8	8	8
B01	1	1	1
B03	1	1	1
B04	1	1	1
B05	1	1	1
B11	7	7	10
B12	7	7	10
B13	6	6	6
B17	1	1	1
B23	8	9	10
B27	8	9	10
B36	2	2	3
B37	2	2	3
B44	1	1	1
B46	2	2	2
B47	1	1	1
B54	30	43	44
B55	30	43	44
B82	25	38	38
B89	7	8	9
C04	1	1	1
C07	32	45	46
C13	36	48	48
C29	1	1	1
C30	1	1	1
C31	50	63	64
C36	1	1	1
D01	4	4	4
D02	13	13	13
D03	65	65	65
D04	12	12	12
D05	1	1	1
D14	1	1	1
D32	36	48	48
D33	36	48	48
E03	1	1	1
F01	10	11	12
F08	2	2	3
F09	2	2	3
G01	1	1	1
G02	2	2	2
G03	1	1	1
L02	12	12	12
X02	1	1	1

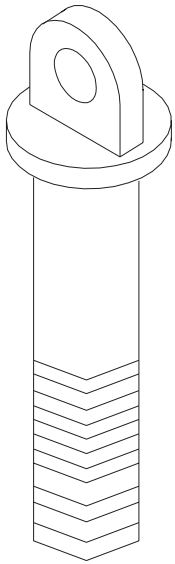

B01

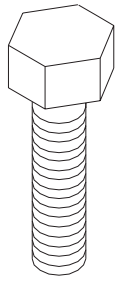

B44

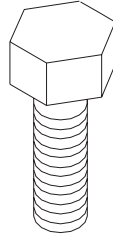

B89

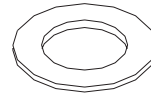

B27

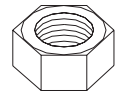

B23

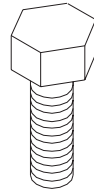

B55



B54

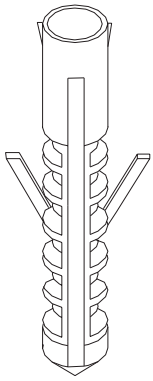

B12

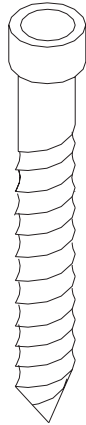

B11

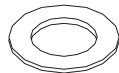

C29

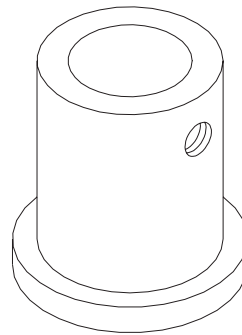

F01



C31



C13



B82

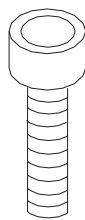

B36



B37

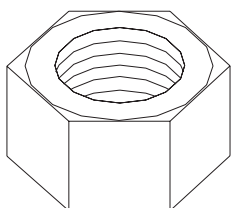

B03

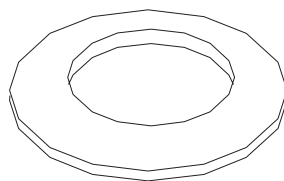

B04



X02

TAB.2

To determine the necessary number of spacers (D03), you must look-up the table TAB.2 (H = Height, A = Rises).

Example: given a floor-to-floor height of 298cm (9' 9 3/8") and a staircase with 13 treads, you must proceed as follows;

1. At height (298cm (9' 9 3/8")) in the row H) look-up the number of necessary spacers (i.e. 50 spacers in the row A/13)
2. Distribute the spacers (D03), one at a time, among the combined parts D14-D04 and D02 all (for the single spacer D14 you can use at the most 3 spacers (D03); for the spacers (D04) you can use at the most 5 spacers (D03).
3. The final result is the following : 3 spacers (D03) between D14 and D02, 3 more spacers (D03) on a spacer chosen between D04 and D02 and 4 spacers (D03) between D04 and D02 of the remaining eleven spacers.

TAB. 2

	A		H		A		H		A		H		A	
H	10		11		12	KIT	13		14		15		16	
210	0				252	0			294	0			336	0
211	2				253	2			295	2			337	2
212	4				254	4			296	4			338	4
213	6				255	6			297	6			339	6
214	8				256	8			298	8			340	8
215	10				257	10			299	10			341	10
216	12				258	12			300	12			342	12
217	14				259	14			301	14			343	14
218	16				260	16			302	16			344	16
219	18				261	18			303	18			345	18
220	20				262	20			304	20			346	20
221	22				263	22			305	22			347	22
222	24				264	24			306	24			348	24
223	26				265	26			307	26			349	26
224	28				266	28			308	28			350	28
225	30				267	30			309	30			351	30
226	32				268	32			310	32			352	32
227	34				269	34			311	34			353	34
228	36				270	36			312	36			354	36
229	38				271	38			313	38			355	38
230	40				272	40			314	40			356	40
231	42		0		273	42		0	315	42		0	357	42
232	44		2		274	44		2	316	44		2	358	44
233	46		4		275	46		4	317	46		4	359	46
234	48		6		276	48		6	318	48		6	360	48
235	50		8		277	50		8	319	50		8	361	50
236			10		278	52		10	320	52		10	362	52
237			12		279	54		12	321	54		12	363	54
238			14		280	56		14	322	56		14	364	56
239			16		281	58		16	323	58		16	365	58
240			18		282	60		18	324	60		18	366	60
241			20		283			20	325	62		20	367	62
242			22		284			22	326	64		22	368	64
243			24		285			24	327	66		24	369	66
244			26		286			26	328	68		26	370	68
245			28		287			28	329	70		28	371	70
246			30		288			30	330			30	372	72
247			32		289			32	331			32	373	74
248			34		290			34	332			34	374	76
249			36		291			36	333			36	375	78
250			38		292			38	334			38	376	80
251			40		293			40	335			40	377	
252			42		294			42	336			42	378	
253			44		295			44	337			44	379	
254			46		296			46	338			46	380	
255			48		297			48	339			48	381	
256			50		298			50	340			50	382	
257			52		299			52	341			52	383	
258			54		300			54	342			54	384	
259					301			56	343			56	385	
260					302			58	344			58	386	
261					303			60	345			60	387	
262					304			62	346			62	388	
263					305			64	347			64	389	
264					306				348			66	390	
265					307				349			68	391	
266					308				350			70	392	
267					309				351			72	393	
268					310				352			74	394	
269					311				353				395	
270					312				354				396	
271					313				355				397	
272					314				356				398	
273					315				357				399	

TAB. 2

	A		A		A		A		A		A		
H		H		H		H		H		H			
	10		11		12	<i>KIT</i>	13		14		15		16
6'10 5/8"	0			8' 3 1/4"	0			9' 7 3/4"	0			11' 1/4"	0
6'11 1/8"	2			8' 3 5/8"	2			9' 8 1/8"	2			11' 5/8"	2
6'11 1/2"	4			8' 4 "	4			9' 8 1/2"	4			11' 1 1/8"	4
6'11 7/8"	6			8' 4 3/8"	6			9' 8 7/8"	6			11' 1 1/2"	6
7' 1/4"	8			8' 4 3/4"	8			9' 9 3/8"	8			11' 1 7/8"	8
7' 5/8"	10			8' 5 1/8"	10			9' 9 3/4"	10			11' 2 1/4"	10
7' 1 "	12			8' 5 5/8"	12			9' 10 1/8"	12			11' 2 5/8"	12
7' 1 3/8"	14			8' 6 "	14			9' 10 1/2"	14			11' 3 "	14
7' 1 7/8"	16			8' 6 3/8"	16			9' 10 7/8"	16			11' 3 3/8"	16
7' 2 1/4"	18			8' 6 3/4"	18			9' 11 1/4"	18			11' 3 7/8"	18
7' 2 5/8"	20			8' 7 1/8"	20			9' 11 3/4"	20			11' 4 1/4"	20
7' 3 "	22			8' 7 1/2"	22			10' 1/8"	22			11' 4 5/8"	22
7' 3 3/8"	24			8' 8 "	24			10' 1/2"	24			11' 5"	24
7' 3 3/4"	26			8' 8 3/8"	26			10' 7/8"	26			11' 5 3/8"	26
7' 4 1/4"	28			8' 8 3/4"	28			10' 1 1/4"	28			11' 5 3/4"	28
7' 4 5/8"	30			8' 9 1/8"	30			10' 1 5/8"	30			11' 6 1/4"	30
7' 5 "	32			8' 9 1/2"	32			10' 2 "	32			11' 6 5/8"	32
7' 5 3/8"	34			8' 9 7/8"	34			10' 2 1/2"	34			11' 7 "	34
7' 5 3/4"	36			8' 10 1/4"	36			10' 2 7/8"	36			11' 7 3/8"	36
7' 6 1/8"	38			8' 10 3/4"	38			10' 3 1/4"	38			11' 7 3/4"	38
7' 6 1/2"	40			8' 11 1/8"	40			10' 3 5/8"	40			11' 8 1/8"	40
7' 7 "	42		0	8' 11 1/2"	42		0	10' 4 "	42		0	11' 8 1/2"	42
7' 7 3/8"	44		2	8' 11 7/8"	44		2	10' 4 3/8"	44		2	11' 9"	44
7' 7 3/4"	46		4	9' 1/4"	46		4	10' 4 3/4"	46		4	11' 9 3/8"	46
7' 8 1/8"	48		6	9' 5/8"	48		6	10' 5 1/4"	48		6	11' 9 3/4"	48
7' 8 1/2"	50		8	9' 1 "	50		8	10' 5 5/8"	50		8	11'10 1/8"	50
7' 8 7/8"			10	9' 1 1/2"	52		10	10' 6 "	52		10	11'10 1/2"	52
7' 9 1/4"			12	9' 1 7/8"	54		12	10' 6 3/8"	54		12	11'10 7/8"	54
7' 9 3/4"			14	9' 2 1/4"	56		14	10' 6 3/4"	56		14	11'11 1/4"	56
7' 10 1/8"			16	9' 2 5/8"	58		16	10' 7 1/8"	58		16	11'11 3/4"	58
7' 10 1/2"			18	9' 3 "	60		18	10' 7 1/2"	60		18	12' 1/8"	60
7' 10 7/8"			20	9' 3 3/8"			20	10' 8 "	62		20	12' 1/2"	62
7' 11 1/4"			22	9' 3 7/8"			22	10' 8 3/8"	64		22	12' 7/8"	64
7' 11 5/8"			24	9' 4 1/4"			24	10' 8 3/4"	66		24	12' 1 1/4"	66
8' 1/8"			26	9' 4 5/8"			26	10' 9 1/8"	68		26	12' 1 5/8"	68
8' 1/2"			28	9' 5 "			28	10' 9 1/2"	70		28	12' 2 1/8"	70
8' 7/8"			30	9' 5 3/8"			30	10' 9 7/8"			30	12' 2 1/2"	72
8' 1 1/4"			32	9' 5 3/4"			32	10'10 3/8"			32	12' 2 7/8"	74
8' 1 5/8"			34	9' 6 1/8"			34	10'10 3/4"			34	12' 3 1/4"	76
8' 2 "			36	9' 6 5/8"			36	10'11 1/8"			36	12' 3 5/8"	78
8' 2 3/8"			38	9' 7 "			38	10'11 1/2"			38	12' 4 "	80
8' 2 7/8"			40	9' 7 3/8"			40	10'11 7/8"			40	12' 4 3/8"	
8' 3 1/4"			42	9' 7 3/4"			42	11' 1/4"			42	12' 4 7/8"	
8' 3 5/8"			44	9' 8 1/8"			44	11' 5/8"			44	12' 5 1/4"	
8' 4 "			46	9' 8 1/2"			46	11' 1 1/8"			46	12' 5 5/8"	
8' 4 3/8"			48	9' 8 7/8"			48	11' 1 1/2"			48	12' 6 "	
8' 4 3/4"			50	9' 9 3/8"			50	11' 1 7/8"			50	12' 6 3/8"	
8' 5 1/8"			52	9' 9 3/4"			52	11' 2 1/4"			52	12' 6 3/4"	
8' 5 5/8"			54	9' 10 1/8"			54	11' 2 5/8"			54	12' 7 1/8"	
8' 6 "				9' 10 1/2"			56	11' 3 "			56	12' 7 5/8"	
8' 6 3/8"				9' 10 7/8"			58	11' 3 3/8"			58	12' 8 "	
8' 6 3/4"				9' 11 1/4"			60	11' 3 7/8"			60	12' 8 3/8"	
8' 7 1/8"				9' 11 3/4"			62	11' 4 1/4"			62	12' 8 3/4"	
8' 7 1/2"				10' 1/8"			64	11' 4 5/8"			64	12' 9 1/8"	
8' 8 "				10' 1/2"				11' 5"			66	12' 9 1/2"	
8' 8 3/8"				10' 7/8"				11' 5 3/8"			68	12'10 10"	
8' 8 3/4"				10' 1 1/4"				11' 5 3/4"			70	12'10 3/8"	
8' 9 1/8"				10' 1 5/8"				11' 6 1/4"			72	12'10 3/4"	
8' 9 1/2"				10' 2 "				11' 6 5/8"			74	12'11 1/8"	
8' 9 7/8"				10' 2 1/2"				11' 7 "				12'11 1/2"	
8'10 1/4"				10' 2 7/8"				11' 7 3/8"				12'11 7/8"	
8'10 3/4"				10' 3 1/4"				11' 7 3/4"				13' 1/4"	
8'11 1/8"				10' 3 5/8"				11' 8 1/8"				13' 3/4"	
8'11 1/2"				10' 4 "				11' 8 1/2"				13' 1 1/8"	

FIG. 1

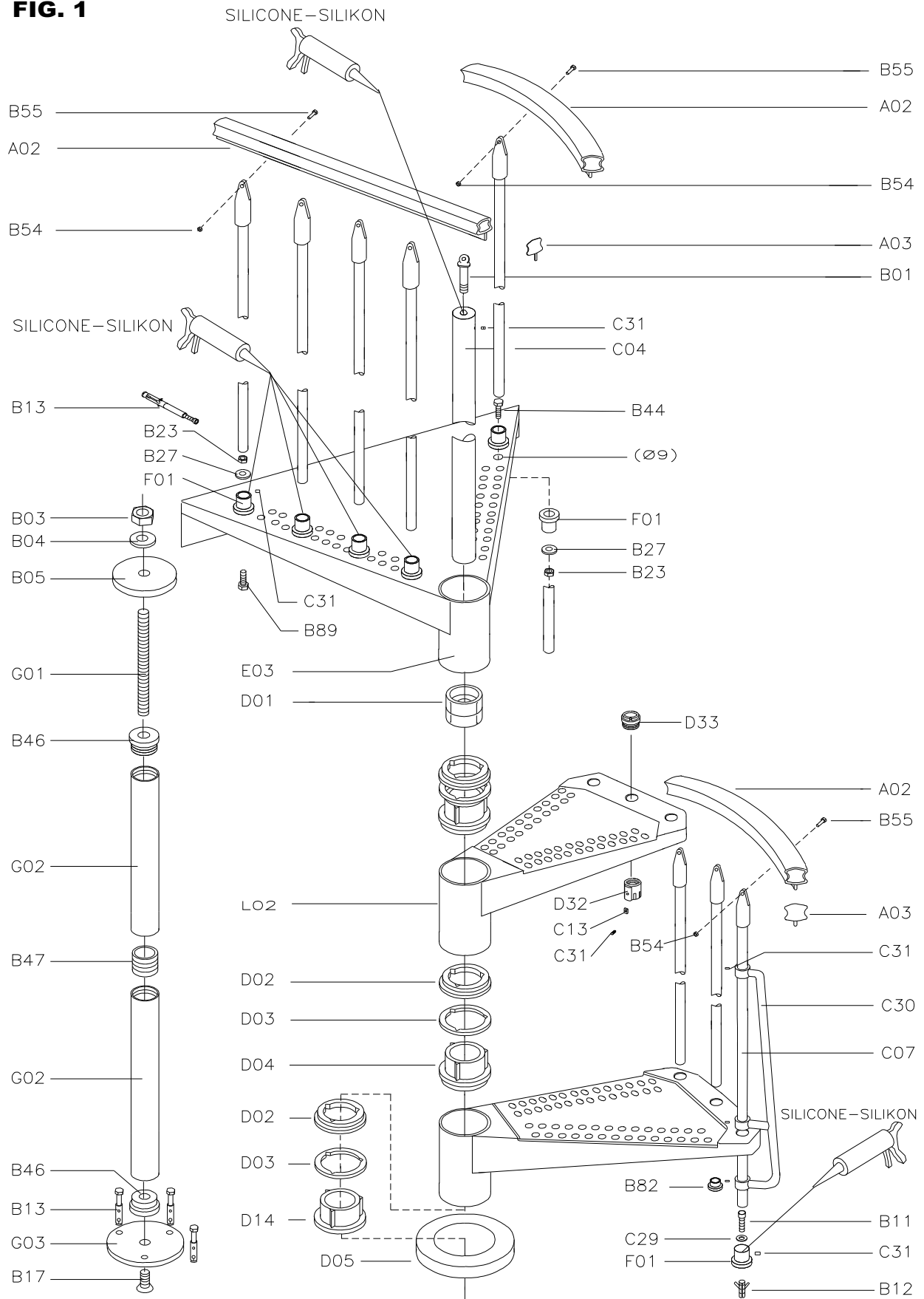

FIG. 2

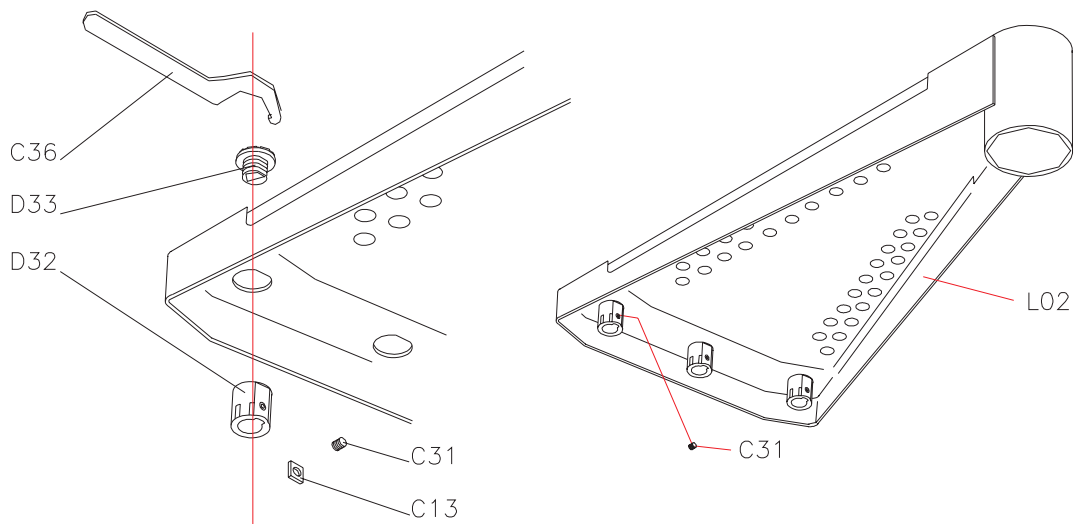

FIG. 3

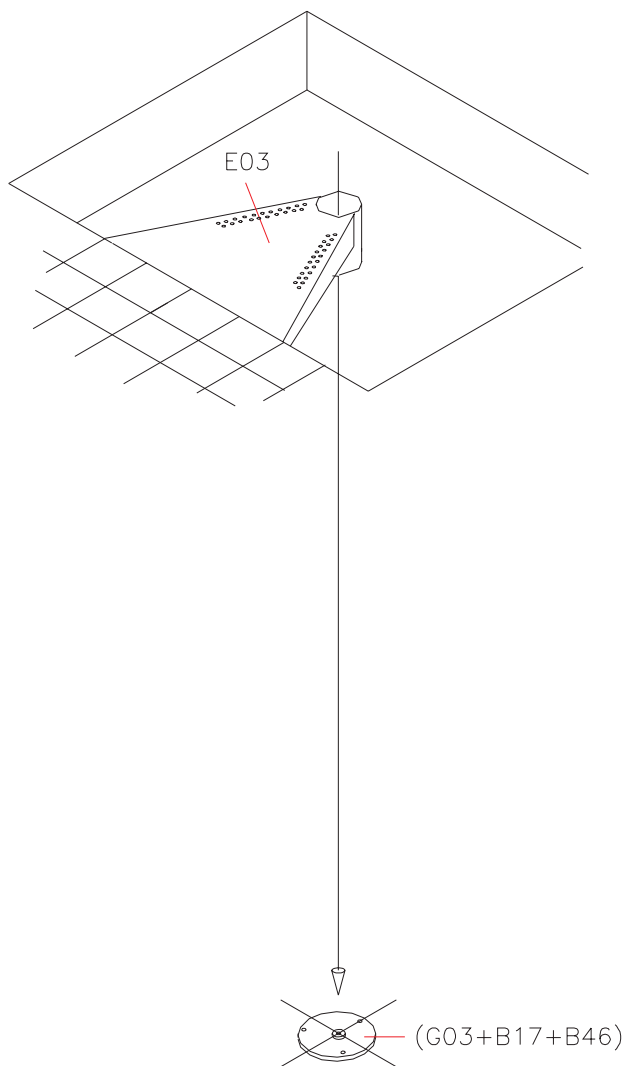

FIG. 4

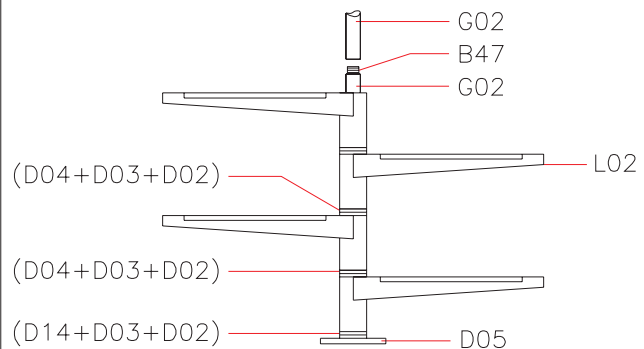

FIG. 5

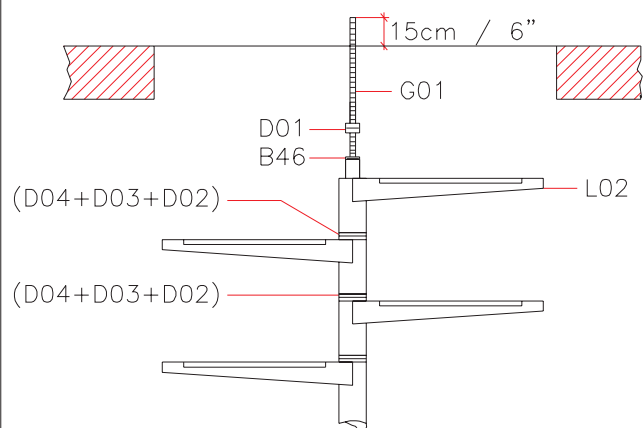
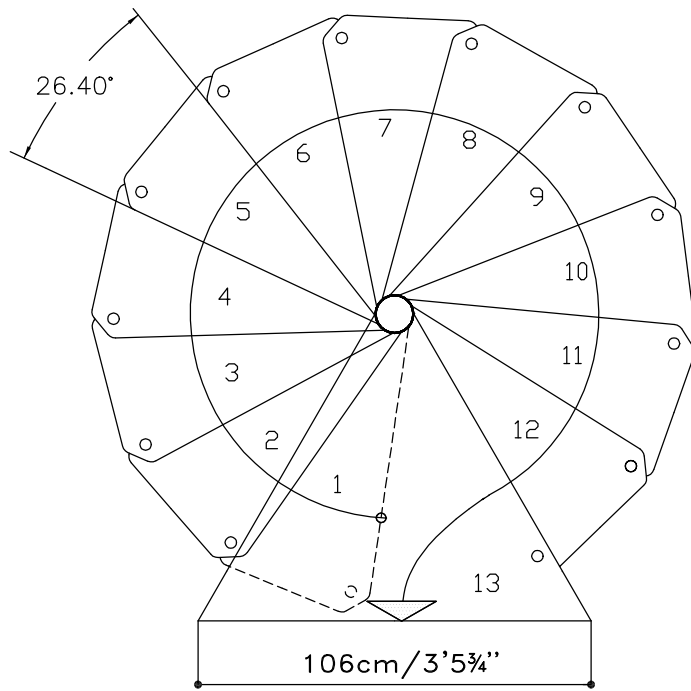
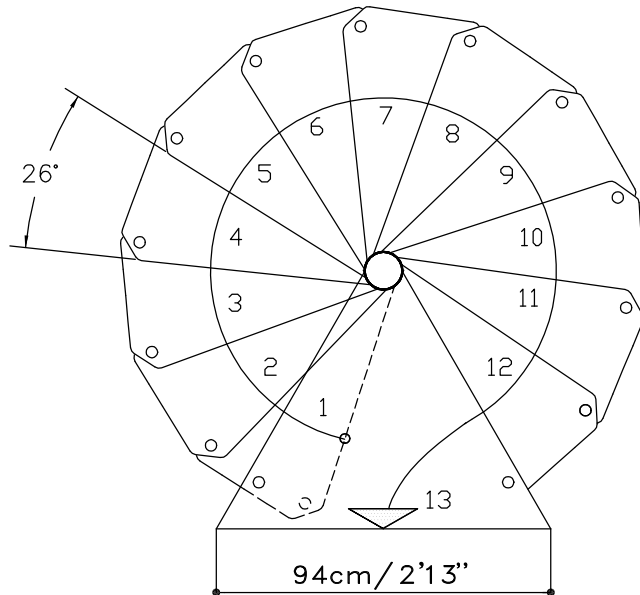
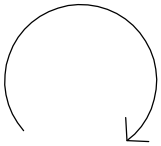

FIG. 6



Ø160 cm
Ø 5'3"



Ø140 cm
Ø 4'7 1/8"

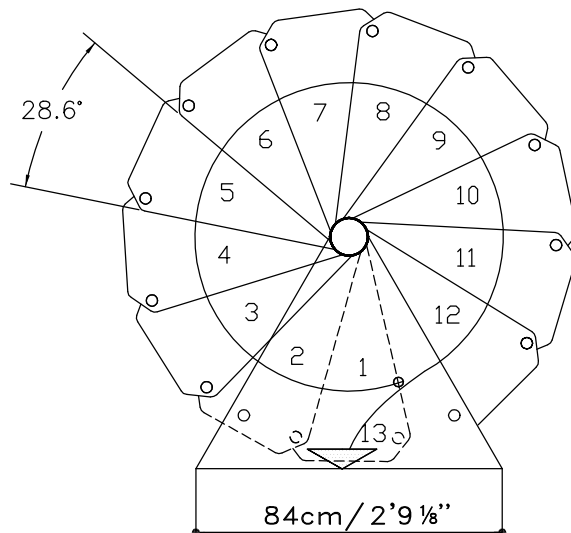
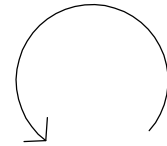

Ø120 cm
Ø 3'11 1/4"

FIG. 7

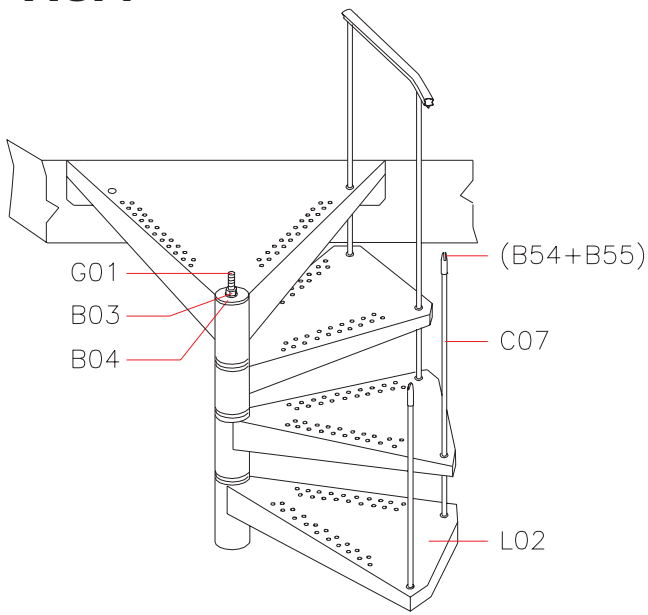

FIG. 8

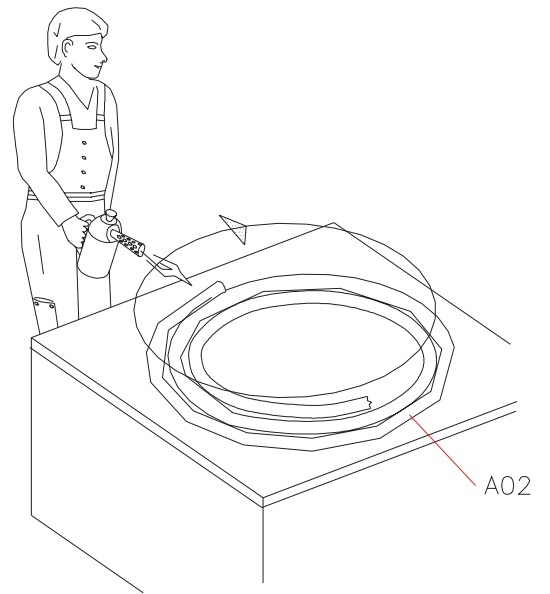

FIG. 9

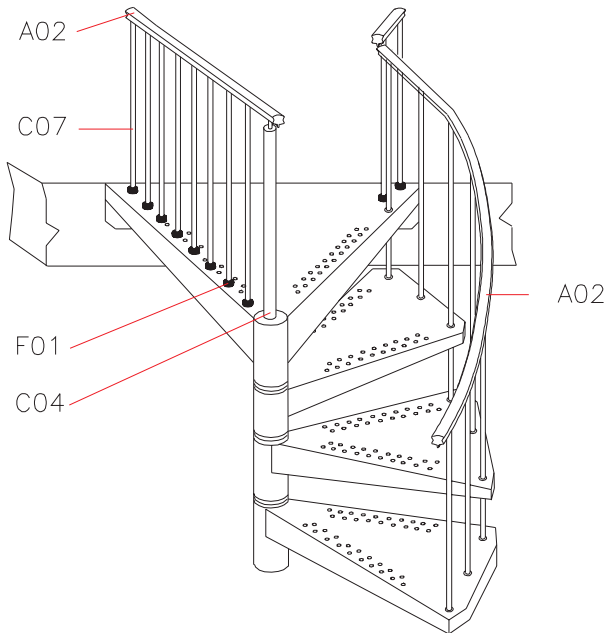

FIG. 10

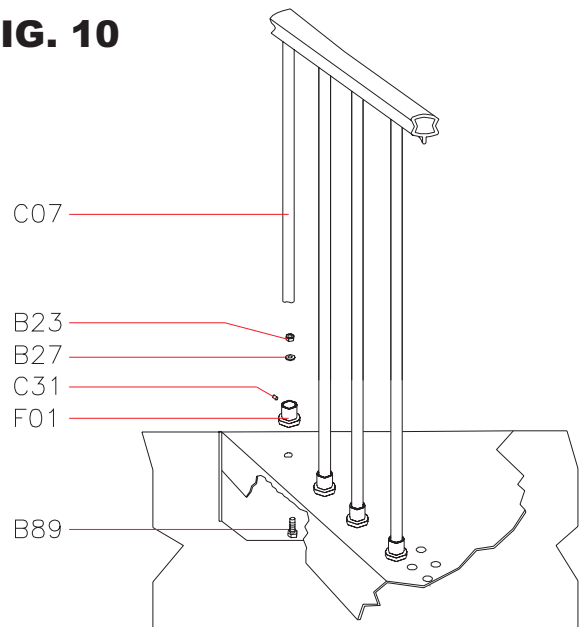
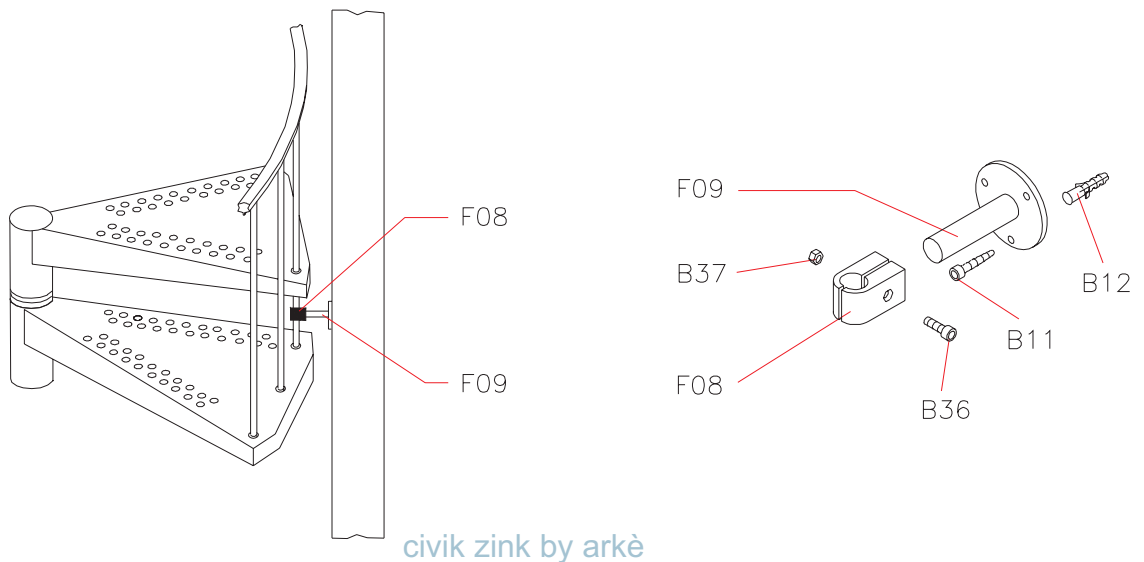

FIG. 11



civik zink by arkè

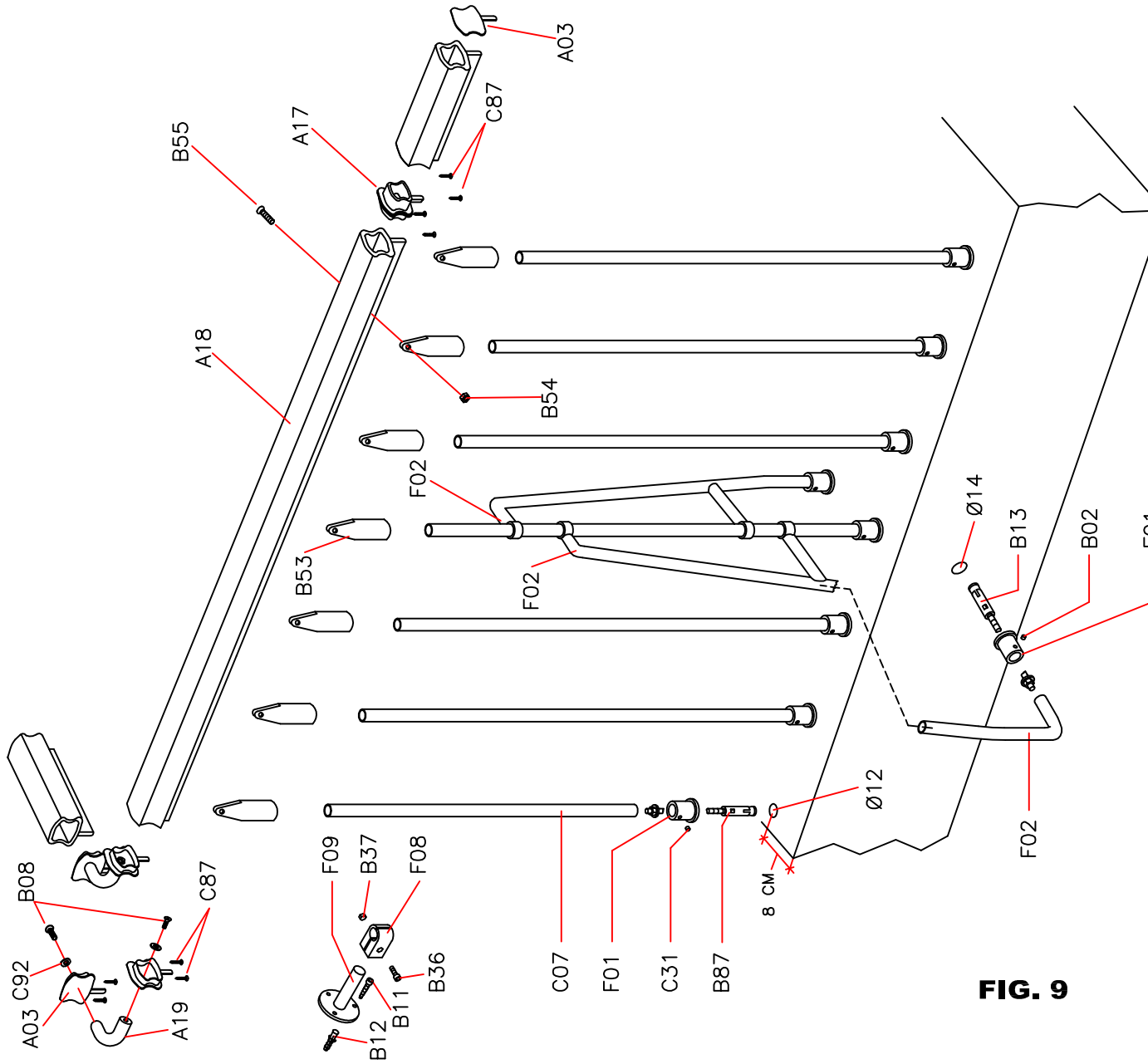
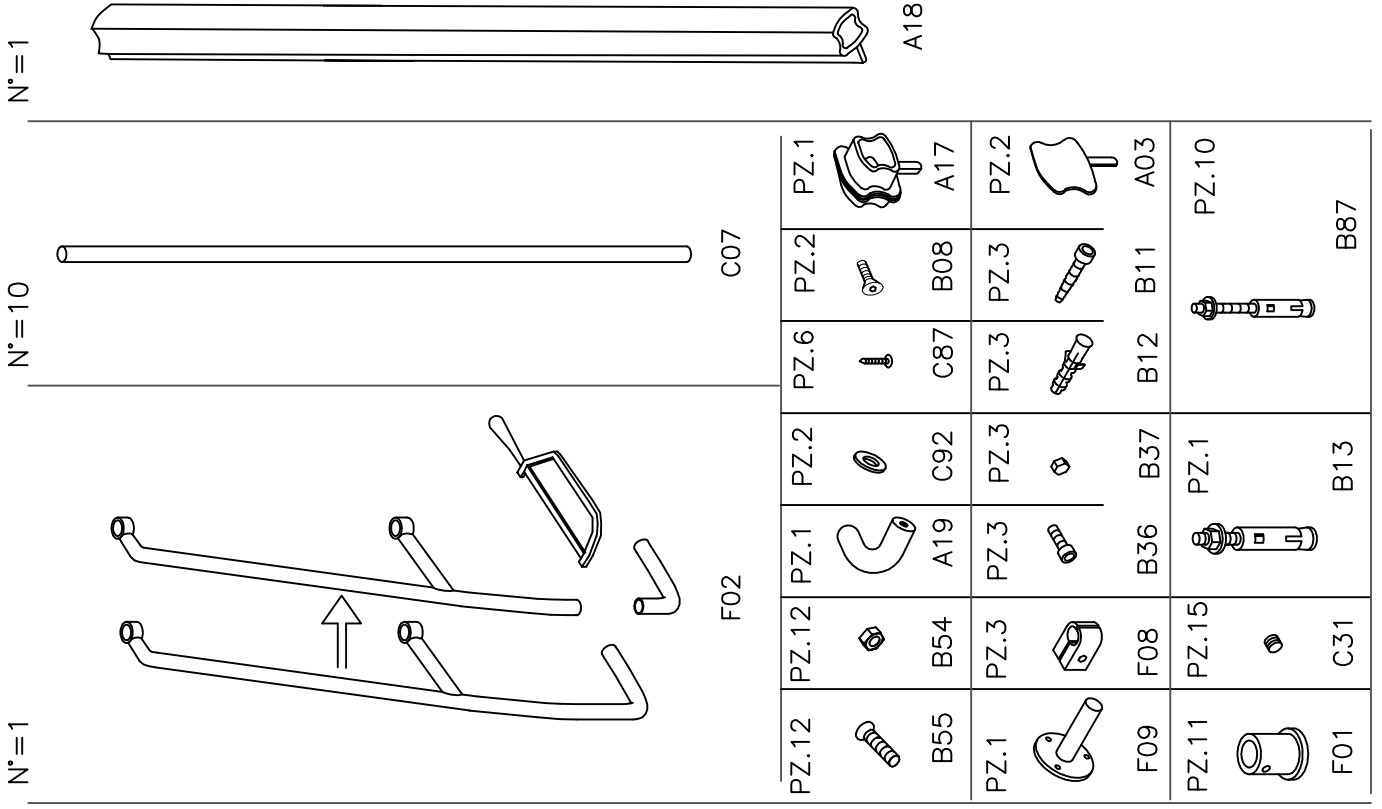

FIG. 9

